

HP Series Linear Pumps

Models HP100, 120, 150 and 200



Model Number	HP100-0110	HP120-0110	HP150-0110	HP200-0110
Voltage (Vac)	120	120	120	120
Frequency (Hz)	60	60	60	60
Max. Cont. Pressure (psig)	4.5	4.5	4.5	5
Max. Inter. Pressure (psig)	6.5	6.5	6.5	6.5
Open Flow (c.f.m.)	5.2	6.1	8.6	10.5
Power Consumption (amps)	1.55	2.1	2.1	3.4
Sound Level (dBA@3 ft.)	38	40	48	47
Weight (lbs.)	19	19	20	20
Service Kit # Chambr. Bck.	120PC20011	120PC20011	200PC20011	200PC20011

Performance data noted is representative of typical values. Specifications and performance data are subject to change without notice. Purchaser is responsible for determining suitability for product applications.

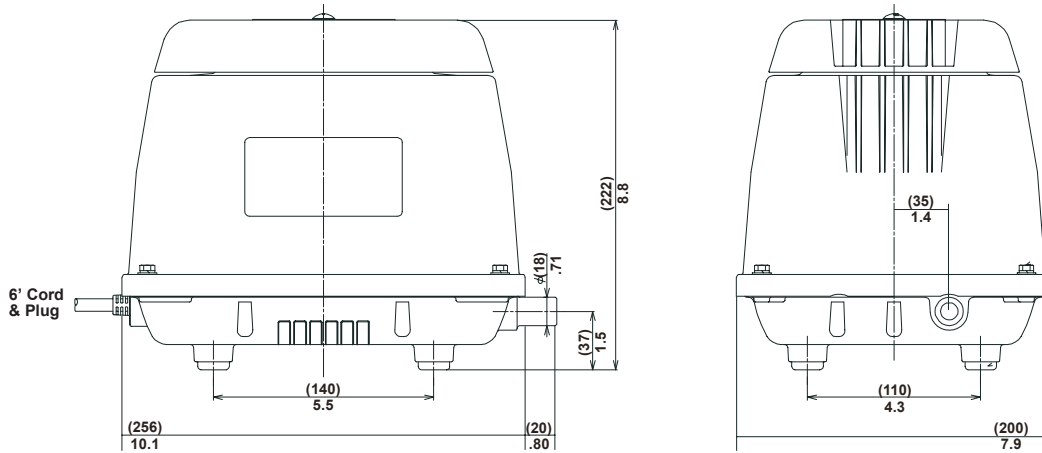

Dimensions in inches & (mm)

HP 100, 120, 150 & 200 PERFORMANCE

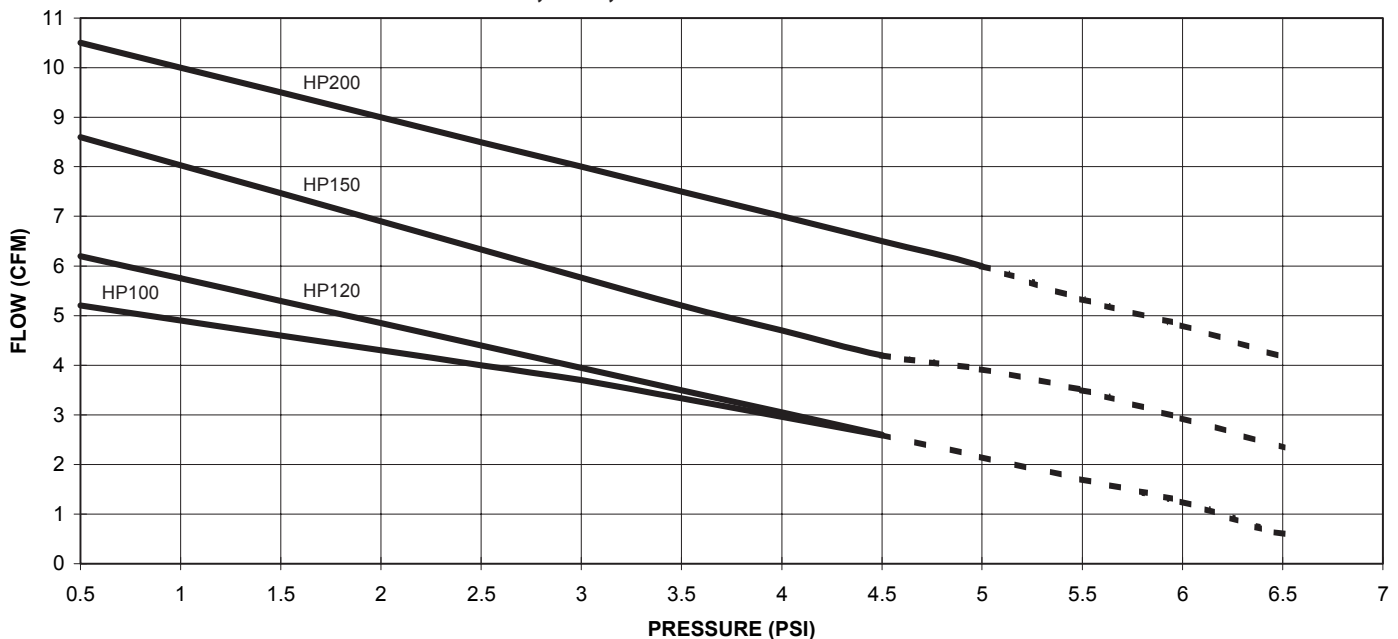

Working Principle

When the alternating current is applied to the electromagnet, the actuating rod moves first in the direction of the arrow as shown in Fig A and then in the direction of the arrow as shown in Fig B, by the magnetic attraction and repellent forces exerted between the electromagnet and the permanent magnets attached to the rod.

The rod vibrates at the same frequency as that of the power supply and changes the volume of space enclosed between the casing and the diaphragm.

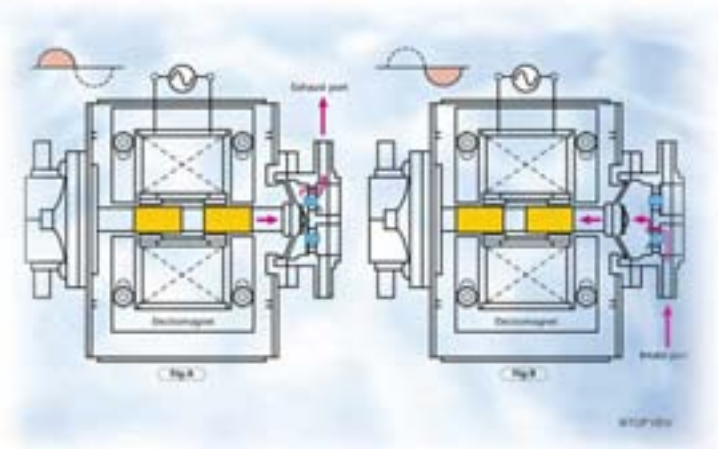

Features

- Quiet Operation
- Low Power Consumption, Vibration, Pulsation and Starting Current
- Oil-less Contamination Free Design
- Long Life
- Automatic Pressure Limitation
- U.L. Outdoor Rating Available on HP Series
- Easy to Service
- Custom OEM Models
- Fast Reliable Shipments/Delivery
- Thermal Protection
- Over Pressurization Protection
- C.E. Compliant and U.L. Listed Models

Product Performance Range

Flows up to 10.5 Cubic Feet per Minute
Pressures up to 7.5 p.s.i.g.

Terms/Conditions

Visit our website www.hiblow-usa.com for current data covering product Terms & Conditions of Sale and Warranty information.

Applications



- Aeration
- Air Purification
- Air Sampling
- Bubble Bath
- Gas Analyzer
- Liquid Agitation
- Medical & Scientific Equipment
- Pneumatic Beds
- Air Mattresses
- Wastewater Treatment
- Aerobic Treatment
- Air Cleaners
- Aquarium
- Ozoning Equipment
- Sequential Compression Devices
- Lift Station Equipment
- Air Massager

